

SMD LED 1206

1. Features

- ☒ Package (L/W/H) : 3.2 × 1.5 × 1.1 mm
- ☒ Color : Ultra Bright Red
- ☒ Lens: Water Clear Flat Mold
- ☒ EIA STD Package
- ☒ Meet ROHS, Green Product
- ☒ Compatible With SMT Automatic Equipment
- ☒ Compatible With Infrared Reflow Solder And Wave Solder Process

Number	Part Number
10x	26006020
20x	26006021
50x	26006022
100x	26006023
200x	26006024

2. Package Profile & Soldering PAD Suggested

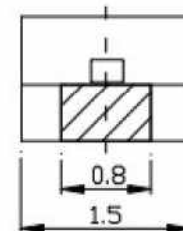
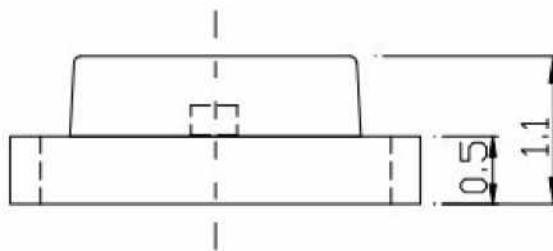
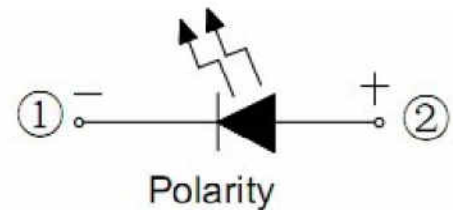
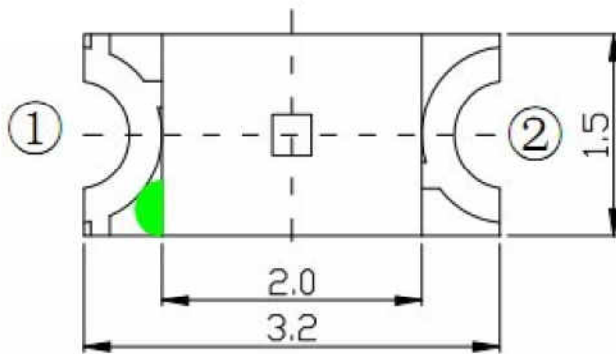

Soldering PAD Suggested:

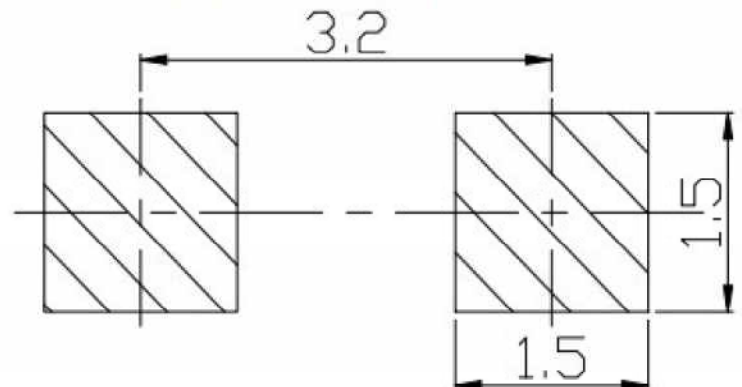
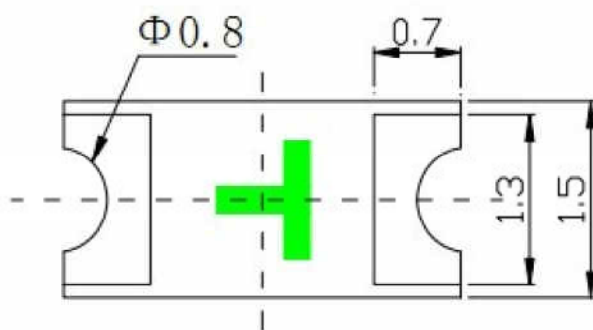

- Notes: 1. All dimensions are in millimeters ;
 2. Tolerance is ± 0.10 mm unless otherwise noted.

SMD LED 1206

3. Soldering Profile Suggested

3.1 For Lead Solder

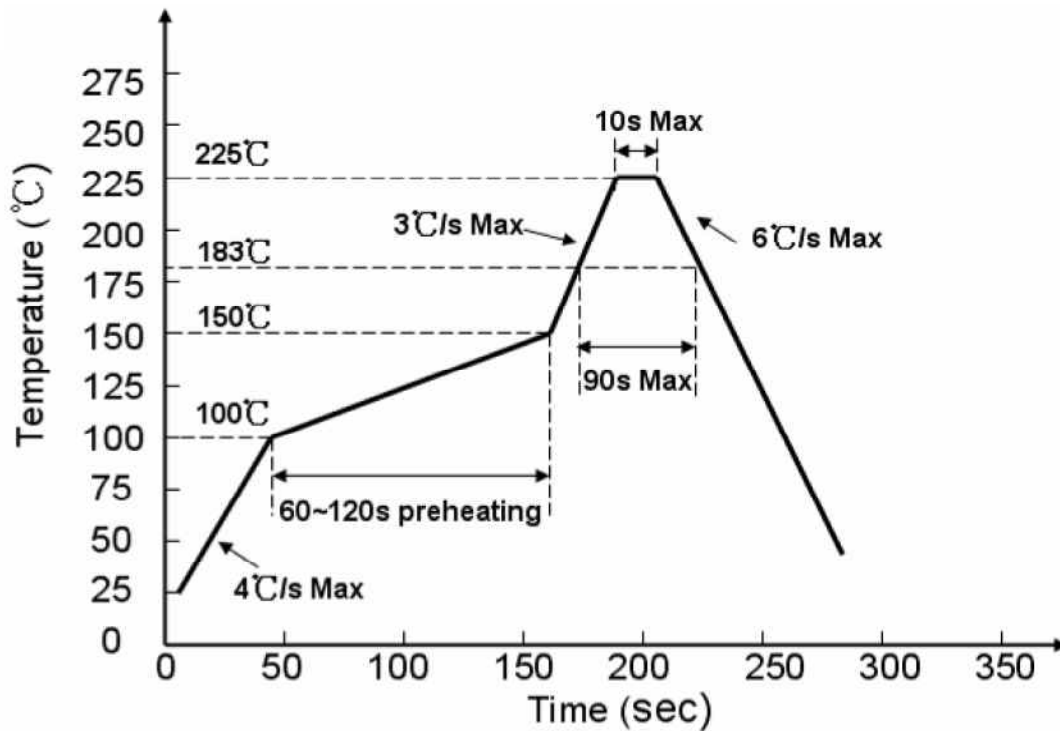

3.2 For Lead Free Solder

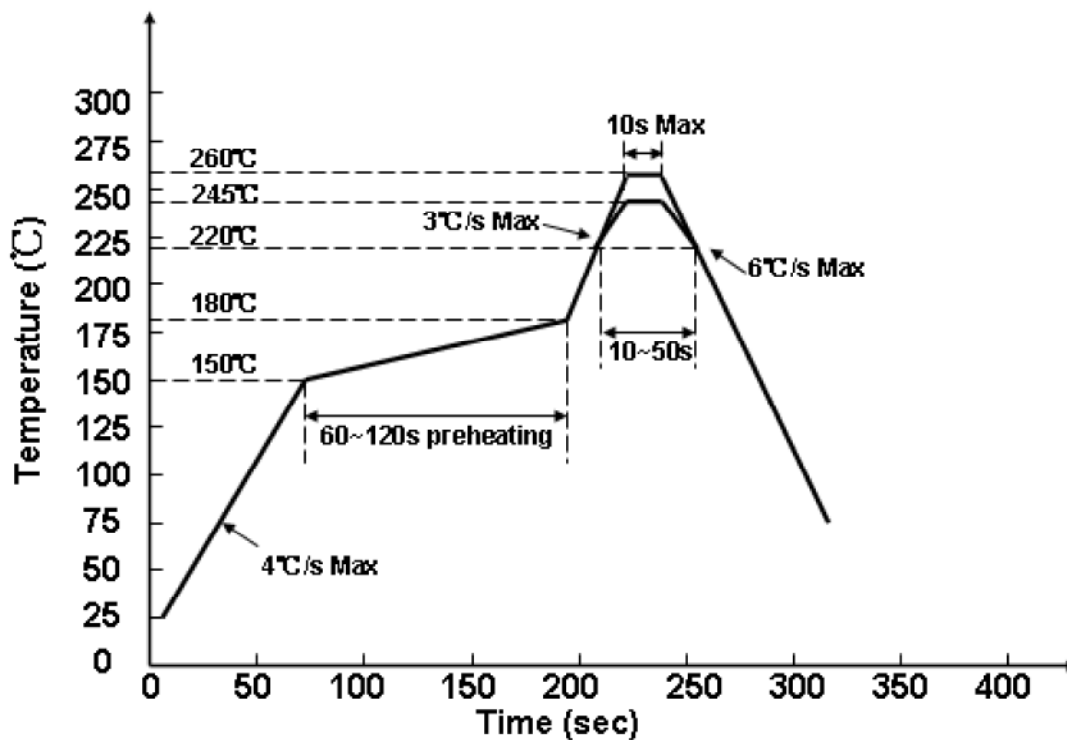

Notes:

We recommend the soldering temperature 245± 5°C ;

The maximum temperature should be limited to 260 °C.

SMD LED 1206

4. Absolute Maximum Ratings At Ta=25

Parameter	Symbol	Rating	Unit
Power Dissipation	Pd	70	mW
Peak Forward Current (1/10 Duty Cycle, 0.1ms Pulse Width)	IFP	70	mA
DC Forward Current	IF	30	mA
Reverse Voltage	VR	5	V
Operating Temperature Range	Topr	-30°C ~ +85°C	
Storage Temperature Range	Tstg	-40°C ~ +90°C	
Soldering Condition	Tsol	Reflow soldering : 260°C For 5 Seconds Hand soldering: 300°C For 3 Seconds	

SMD LED 1206

5. Electrical Optical Characteristics At Ta=25

Parameter	Symbol	Min.	Typ.	Max.	Unit	Test Condition
Luminous Intensity	IV	---	100	---	mcd	IF = 20mA
Viewing Angle	2θ1/2	---	120	---	deg	IF = 20mA
Dominant Wavelength	λd	---	624	---	nm	IF=20mA
Peak Wavelength	λp	---	630	---	nm	IF=20mA
Spectral Line Half-Width	Δλ	---	20	---	nm	IF=20mA
Forward Voltage	VF	1.8	---	2.6	V	IF=20mA
Reverse Current	IR	---	---	10	uA	VR=5V

- Notes: 1. Luminous intensity is measured with a light sensor and filter combination that approximates the CIE eye-response curve.
2. θ1/2 is the off-axis angle at which the luminous intensity is half the axial luminous intensity.
3. The dominant wavelength, λd is derived from the CIE chromaticity diagram and represents the single wavelength which defines the color of the device.

SMD LED 1206

6. Typical Electrical-Optical Characteristics Curves

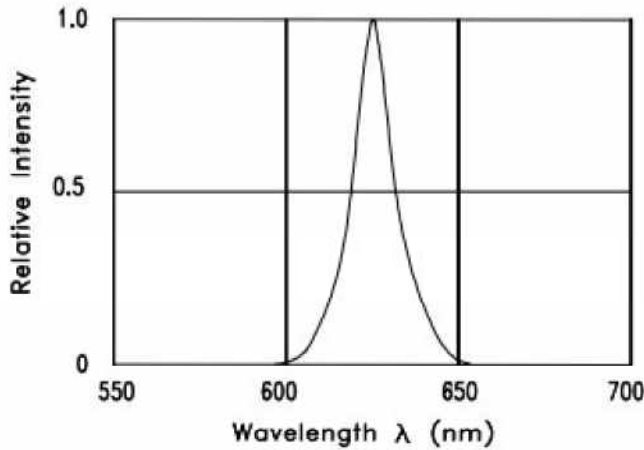

Fig.1 RELATIVE INTENSITY VS. WAVELENGTH

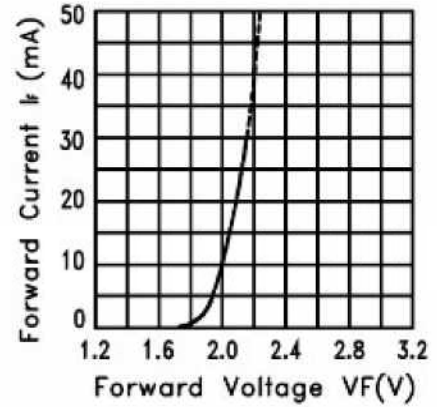

Fig.2 FORWARD CURRENT VS FORWARD VOLTAGE

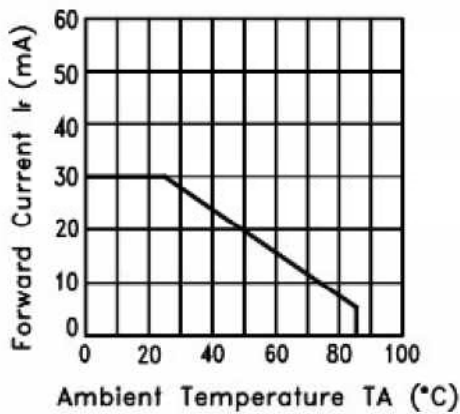

Fig.3 FORWARD CURRENT DERATING CURVE

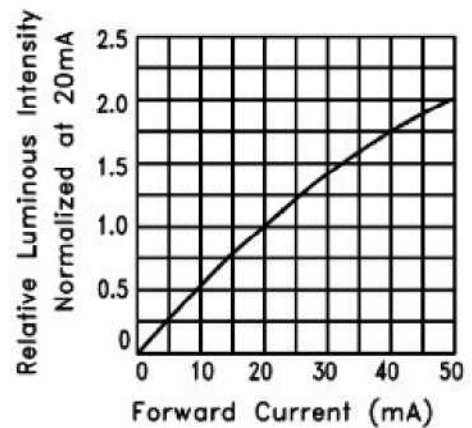

Fig.4 RELATIVE LUMINOUS INTENSITY VS. FORWARD CURRENT

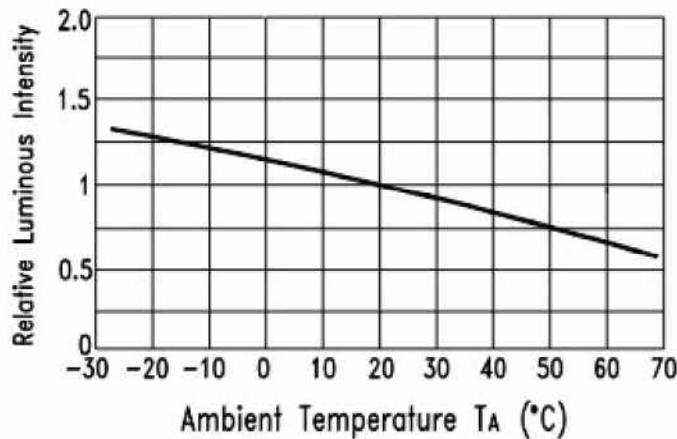

Fig.5 Luminous Intensity vs. Ambient Temperature

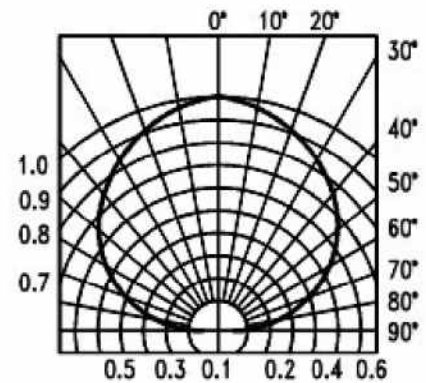

Fig.6 SPATIAL DISTRIBUTION

SMD LED 1206

7.Reel And Tape Dimensions

